

## TRACK AND KEYBOARD MECHANISM

### Hardware Included:

Track Screws  
Bumper  
Track Guard

### Tools Needed:

Phillips Head Screwdriver  
1/8" Drill Bit

①

MOUNT TRAY

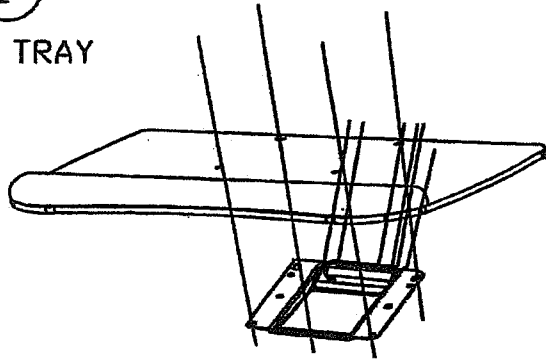

②

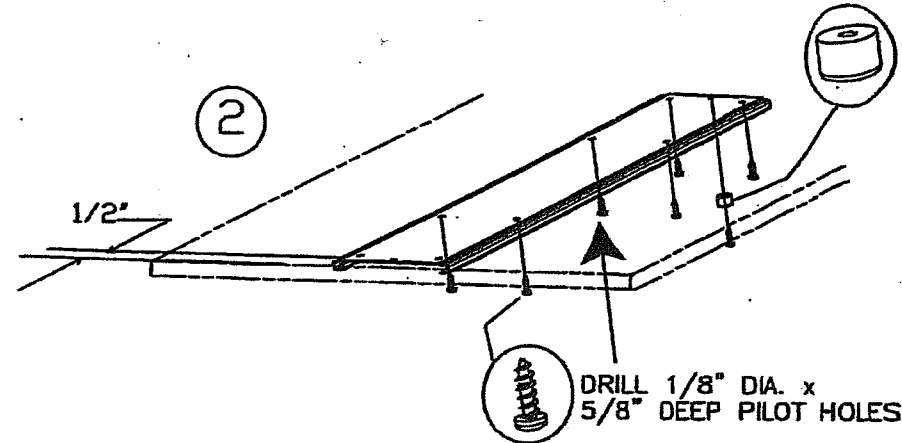

③

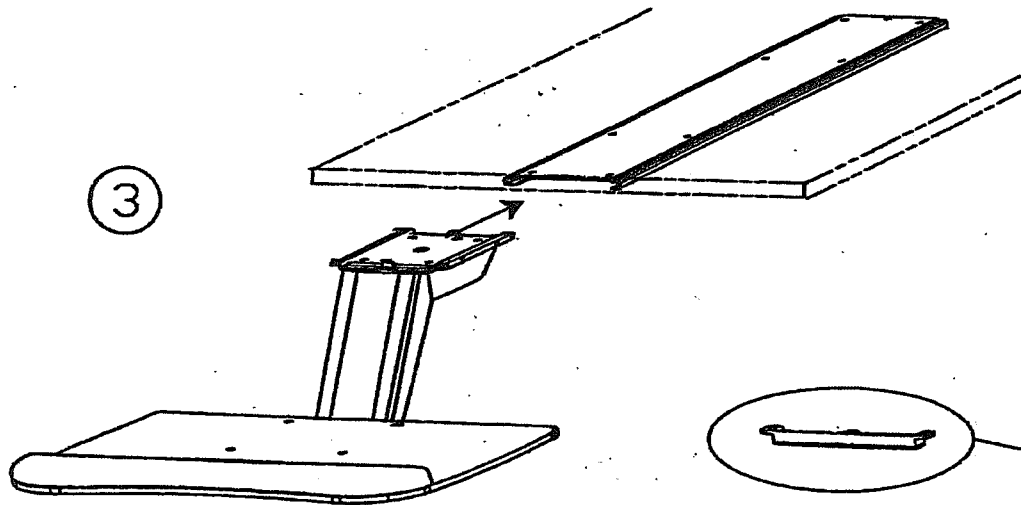

④



# Keyboard Mechanism & MDF Board

## Mounting Instructions

- 1) Mount track to underside of work surface.
  - A. Make sure track is mounted square to front edge of work surface.
  - B. Front edge of track should be approximately 1/2" back from front of work surface.
  - C. Drill (2) pilot holes for the center holes of track using .125" diameter x 5/8" deep in underside of work surface for #10 x 5/8" screws provided.
  - D. Drill (8) pilot holes for the side holes of track using .125" diameter x 5/8" deep in underside of work surface for #10 x 5/8" screws provided.
  - E. Install (8) #10 x 5/8" lg. screws provided along both sides of track and (1) #10x 5/8" lg. back center screw with bumper.
- 2) Mount keyboard tray to articulating arm mechanism.
  - A. If using a supplied keyboard tray, install supplied (6) 3/16 x 1/2" screws into predrilled holes in underside of tray.
  - B. If using another keyboard tray:
    1. Lay tray face down.
    2. Engage operating lever to lock tray bracket.
    3. Use tray bracket holes as a template for marking hole locations. Make sure tray is centered left to right. Back edge of tray bracket must be flush with back edge of tray.
    4. Drill .125" dia. Pilot holes (6) 1/2" deep using #10 x 5/8" screws (not included).
    5. Install screws.
- 3) Slide mechanism into grooves on track approximately 6".
- 4) Disengage operating lever and lower arm mechanism to down position. Engage operating lever to secure mechanism.
- 5) Slide mechanism into grooves on track until it hits back bumper stop.
- 6) Track guard must be installed to ensure product integrity.
- 7) Place track guard over end of track and mark (2) hole locations on work surface. Drill .125" dia. pilot holes 5/8" deep for #10 x 5/8" screws provided. Install track guard. **DO NOT OVERTIGHTEN.**

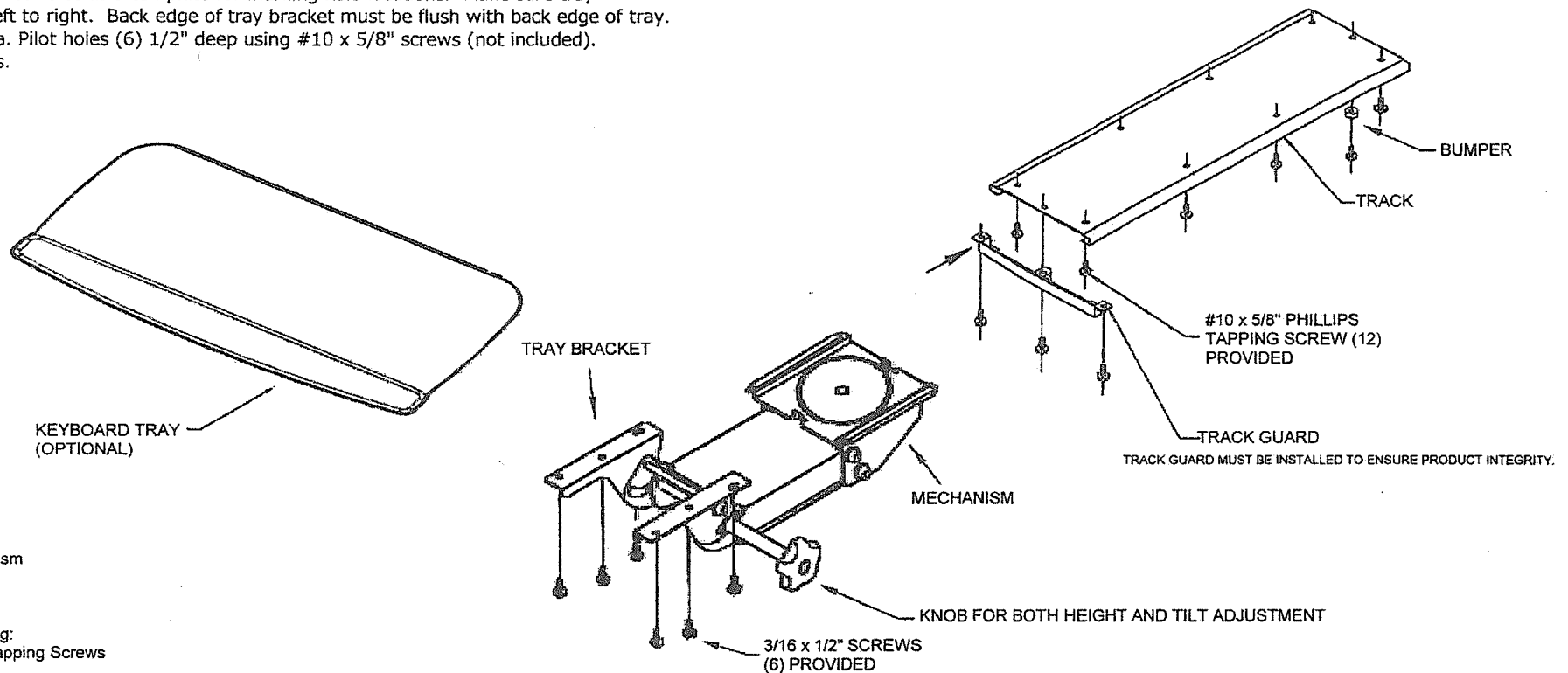

## Parts List

- 1 - Articulating Arm Mechanism
- 1 - Track
- 1 - Keyboard Tray Set
- 1 - Instruction Sheet
- 1 - Accessory Pack. Including:
  - 12 - #10 x 5/8" Phillips Tapping Screws
  - 1 - Bumper
  - 1 - Track Guard
- 1 - Accessory Pack. Including:
  - 6 - 3/16 x 1/2" Screws (only with Keyboard Tray)